



**Plug Seals**

① Buna N. Standard service

**Plug**

② 17-4 PH, API 6A, PSL 3 ASTM

**Valve Body**

③ 4130/4140 forged low alloy steel, API 6A ASTM

**Inserts**

④ Ductile Iron, Phosphate coated

**Adjusting Nut**

⑤ 4130/4140 forged low alloy steel, API 6A ASTM

- Designed to positively shut off or open fully. Not for throttling.
- Balance to reduce operating torque
- Phosphate coating
- QPQ Nitriding
- Full documentation
- Off the shelf availability of spare parts
- Complete traceability of materials
- Design reviews / verification upon customer request
- Testing and inspection - 100%

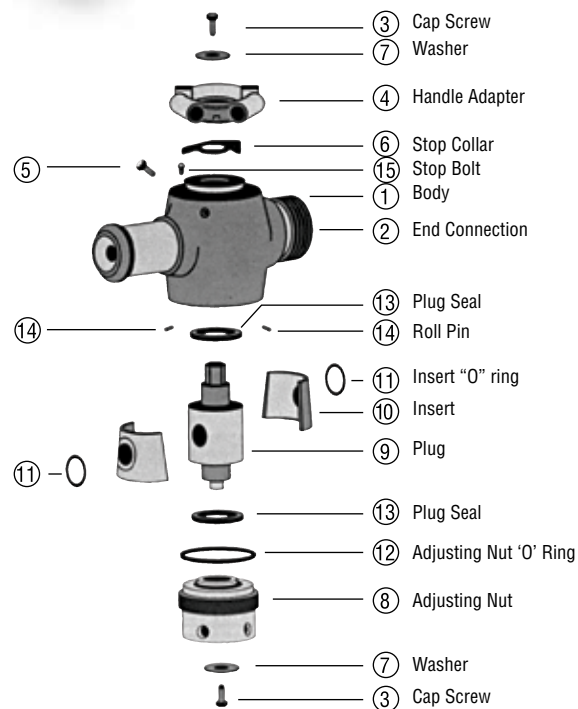

**C&C Plug Valves**

Our valves are built to meet and exceed the industry's most stringent requirements in severe temperature and pressures. The high strength of forged alloy steel bodies and abrasion resisting plug inserts make them most reliable and long lasting.

The valve parts are fully interchangeable with most major designs so they can be used as an integrated part of existing systems. All C&C plug valves are made in compliance with API 6A, Q1 and ISO 9001. They are easy to operate and maintain, and

competitively priced to position themselves among the most desirable quarter turn high performance valves in the market.



**2"x 2" M/F**  
**15,000 WP**  
**22,500 Tested**  
**Integral W/1502 Union Connection**  
**Bore Size 2.06"**  
**Standard Service**



**1"x 2" M/F**  
**15,000 WP**  
**22,500 Tested**  
**Integral W/1502 Union Connection**  
**Bore Size 1"**  
**Standard Service**



**2"x 2" Female**  
**10,000 WP**  
**15,000 Tested**  
**Line Pipe Connection**  
**Bore Size 2.06"**  
**Standard Service**

Plug Valve Specifications					
Valve Description	WP PSIG	Standard Part No.	Wt LBS	Dimensions	
				End to End	Height
1" x 1" 1502 Union	15,000	BH0218	42	10 8/16"	9 1/4"
1" x 2" 1502 Union	15,000	BH0023	52	10 9/16"	9 1/4"
2" x 2" LP Female	10,000	BH0032	74	8 1/2"	10 5/8"
2" x 2" 1502 Union	15,000	BH0006	97	13 7/8"	10 5/8"

**3" is coming soon**

Replacement Parts For Standard Service Plug Valves					
DWG No.	Description	QTY	Valve Size and Part No.		
			1"	2"	
10	Insert Set	1	BH0036	BH0027	
9	Plug	1	BH0037	BH0024	
	Seal Kit	1	BH0065	BH0067	
	Repair Kit	1	BH0071	BH0078	
14	Roll Pin	2	BH0003	BH0003	
5	Grease fittings	1	BH0001	BH0001	
4	Handle Adapter	1	BH0063	BH0062	
6	Stop Collar	1	N/A	BH0061	