

C&C INDUSTRIES INC.

# NON-FREEZE TANK VALVE

**HANDWHEEL: PROVIDES LOW TORQUE OPERATION EVEN DURING THE HARSHTEST WINTER CONDITIONS.**

**STEM: 410 SS STEM IS DESIGNED TO PROVIDE MAXIMUM STRENGTH AND CORROSION RESISTANCE.**

**TAG: CLEARLY DISPLAYS MANUFACTURER, SIZE, AND PART NUMBER.**

**PACKING GLAND: IS EASILY ADJUSTABLE AND EXTENDS VALVE LIFE.**

**NPT THREADS: ALLOW FOR EASY CONNECTION TO TANK AND VALVE OUTLET, AND ELIMINATES THE NEED FOR A PIPE NIPPLE.**

**VALVE BODY: EXTENDS INTO THE TANK MEDIUM, ALLOWING FLUID TO BE PULLED FROM THE CENTER OF THE TANK INSTEAD OF FROM THE EDGE OF THE TANK.**

**VALVE SEAT: IS CONSTRUCTED OF BUNA-N, AND WILL WITHSTAND CONTINUED EXPOSURE TO HYDROCARBONS WITHOUT DETERIORATION.**

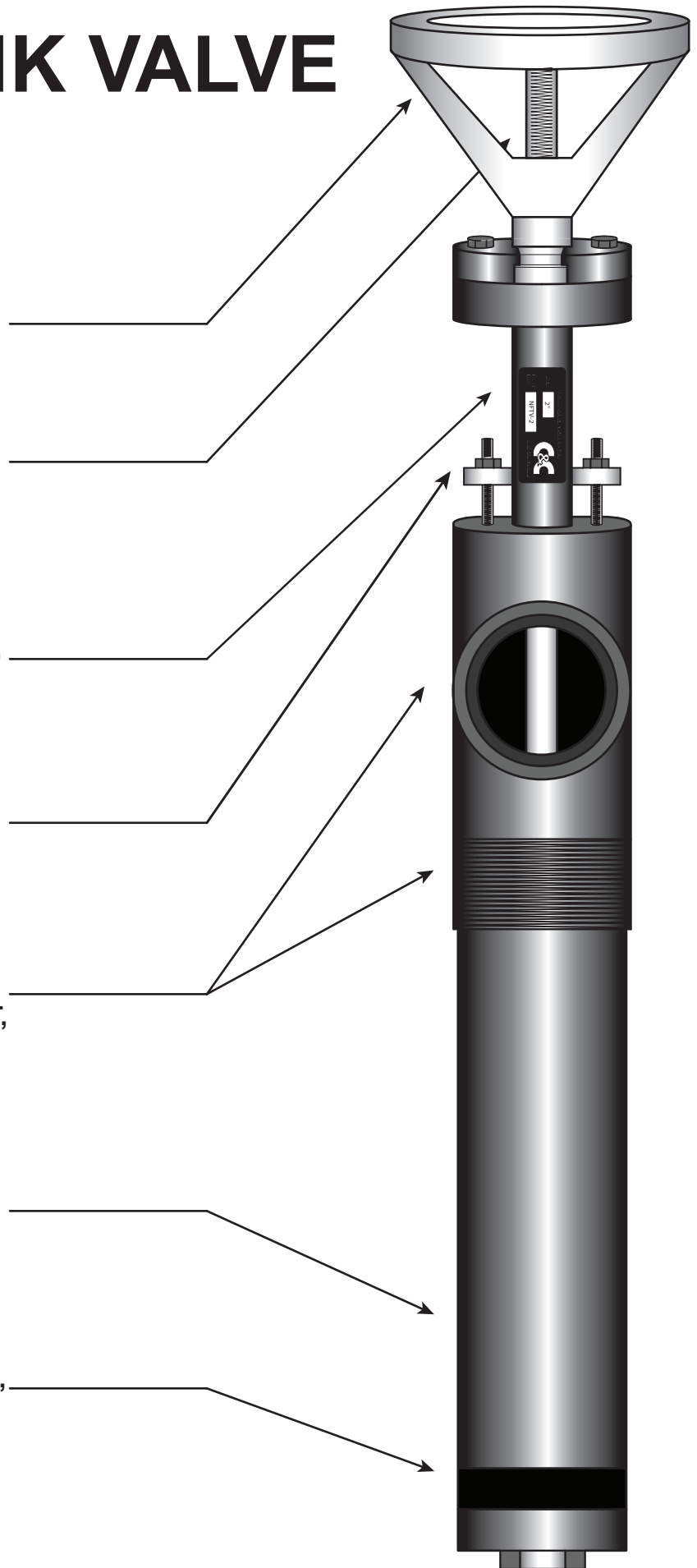

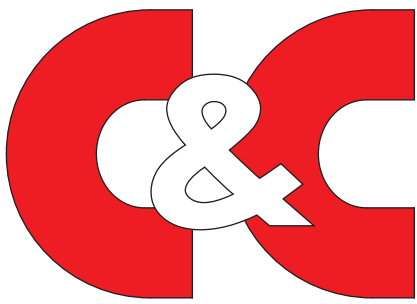

C&C INDUSTRIES INC.

# NON-FREEZE TANK VALVE

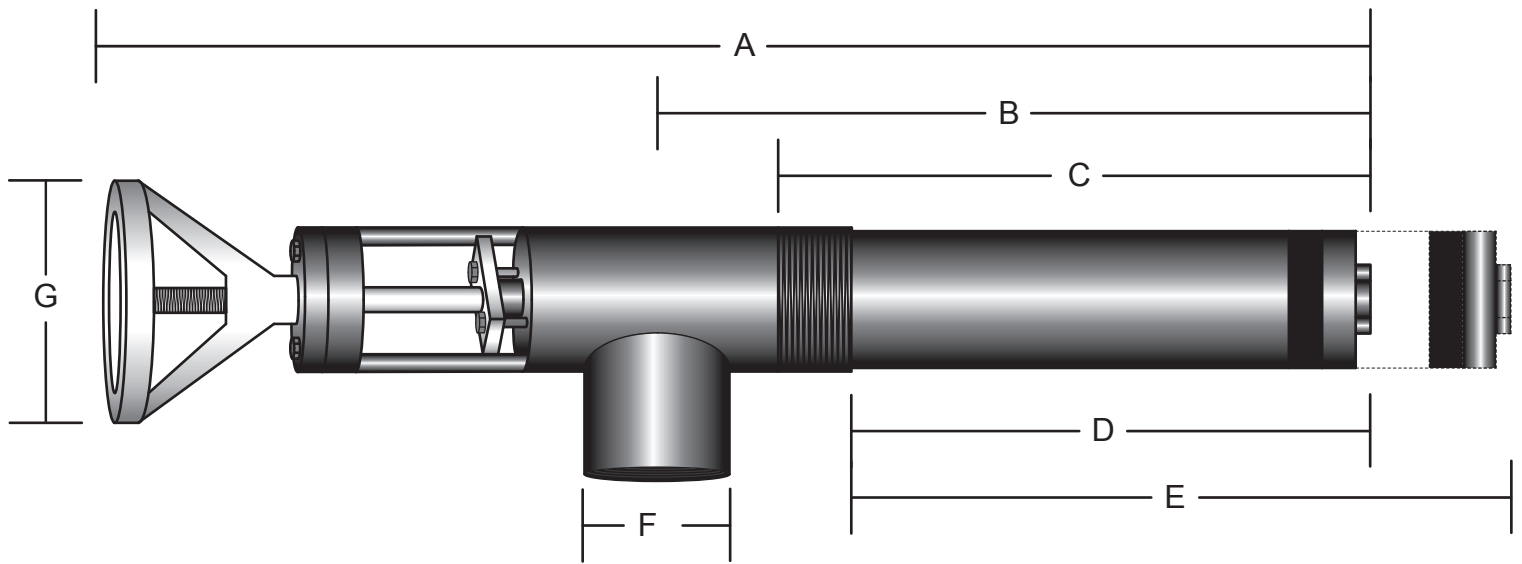

<u>COMPLETE VALVE</u>		<u>NON FREEZE TANK VALVE DIMENSIONS IN INCHES</u>						
PART No.	SIZE	A	B	C	D	E	F	G
NFTV-2	2"	22	13.1/4	10.5/8	9.1/4	10.3/4	2.1/8	5
NFTV-3	3"	25	15.1/4	12	10	11.3/4	3.1/8	5