

# LN200 Series

## Short Neck Butterfly Valve

The C & C LN200 is the perfect choice for work areas with space constraints. Its shorter neck makes the LN200 an ideal valve for trucks, trailers, tanks, or anywhere a compact valve may be desirable. The LN200 is designed with notches in the body, to guide flange bolts during installation, and to keep the valve aligned with the flange during use. The LN200 is designed with a two piece stem which allows for maximum flow values, and for repair of valve parts without special tools. The LN200 is pressure rated to 200 PSI and is available in sizes 2" through 12".

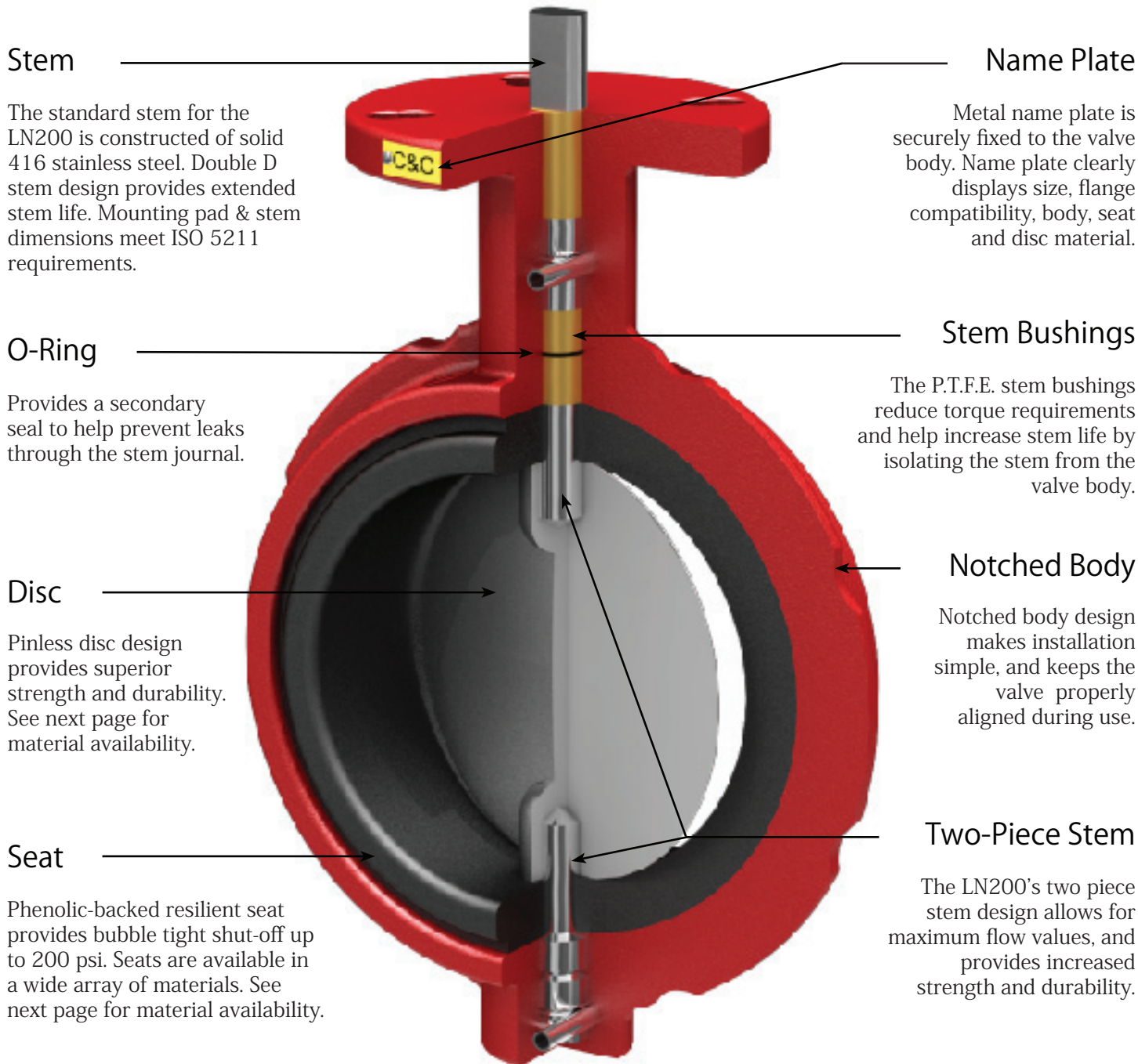

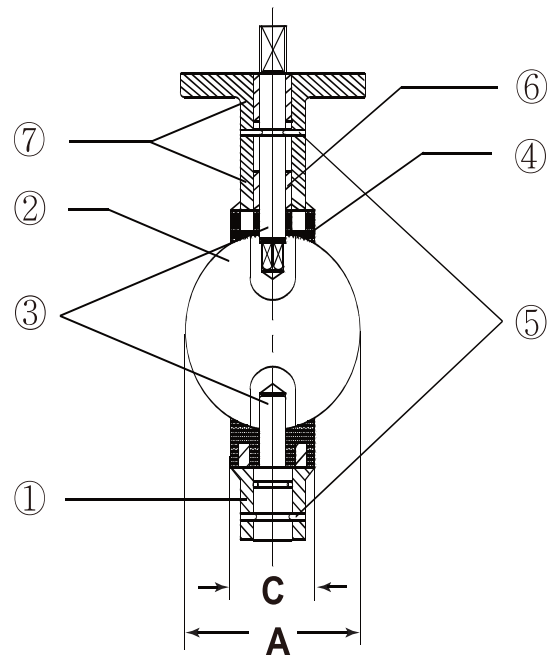
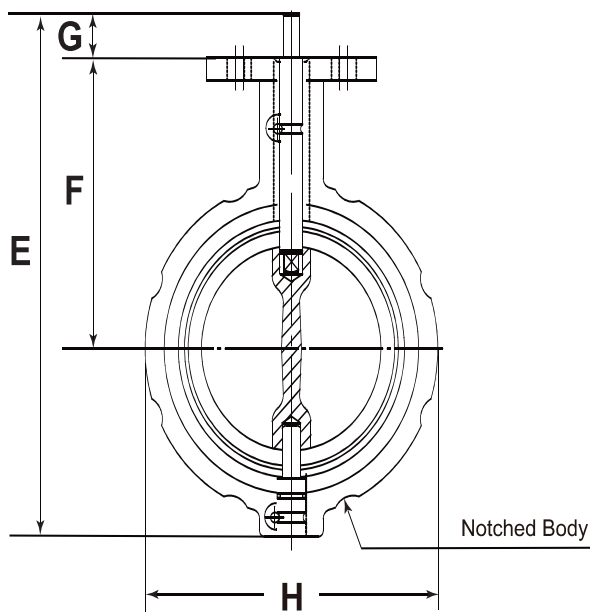

## Materials of Construction

No.	Description	Material
1	Body	Ductile Iron ASTM A536, WCB Gr 216A*, A351 CF8M*, A351 CF8*
2	Disc	Ductile Iron (Ni Plated), Ductile Iron (Nylon Coated), Aluminum Bronze, CF8M (316 SS), CF8 (304 SS)*, Monel**
3	Stem	416 Stainless Steel, 304 Stainless Steel*, 316 Stainless Steel*, Monel**
4	Seat	BUNA-N, E.P.D.M., F.K.M.(Viton®), P.T.F.E. (Teflon®), Neoprene®, Hypalon**
5	Retainer Pin	ASTM Gr. 1065 Steel
6	O-ring	BUNA-N (Viton® Optional)
7	Bushing	P.T.F.E.

\*Asterisk denotes factory availability only

## Dimensional Data

Size	A		C		E		F		G		H		Wafer Weight	
	in	mm	in	mm	in	mm	in	mm	in	mm	in	mm	lbs	Kg
2"	2.07	52.60	1.65	42.04	7.99	203.00	3.93	100.00	1.25	32.00	4.11	104.60	8	4
2.5"	2.53	64.30	1.75	44.68	8.77	223.00	4.44	113.00	1.25	32.00	4.88	124.00	10	5
3"	3.10	78.80	1.77	45.21	9.40	239.00	4.86	123.45	1.25	32.00	5.37	136.60	11	5
4"	4.09	104.04	2.05	52.07	11.14	283.00	5.98	152.00	1.25	32.00	6.87	174.70	13	6
5"	4.85	123.30	2.14	54.36	11.61	295.00	5.98	152.00	1.25	32.00	7.50	190.70	18	8
6"	6.11	155.38	2.19	55.75	12.75	324.00	6.50	165.10	1.25	32.00	8.74	222.20	20	9
8"	7.95	202.15	2.38	60.58	15.94	405.00	8.06	204.73	1.77	45.00	11.00	279.40	35	16
10"	9.84	250.15	2.58	65.63	19.17	487.00	9.97	253.24	1.77	45.00	13.37	339.80	47	21
12"	11.86	301.45	3.02	76.90	22.16	563.00	10.90	277.10	1.77	45.00	15.23	387.00	77	35