

# ***FLOATING BALL VALVES***



**FORCE**

## QUALITY

**FORCE**® Valve quality is guaranteed by the strictest adherence to the **ISO 9000** and **API Q1** audited quality standards. We at **FORCE**® Valve have dedicated ourselves to providing the highest quality valve products to meet our customers expectations. **FORCE**® Valves are manufactured in strict accordance with all applicable ANSI, API and other standards.

Every valve is tested and documented to the API 598 and API 6D testing requirements. Our valves are manufactured to comply with NACE standards with complete MTR traceability.

## FIGURE NUMBER CODING CHART

BF		1		1		A		A		A		1		L	
VALVE TYPE		BORE		PRESSURE CLASS		BODY MATERIAL		TRIM MATERIAL		SEAT MATERIAL		END CONNECTION		OPERATOR	
BU	1 PIECE BALL VALVE	1	FULL	1	CLASS 150	A	A216-WCB(A105)	A	CS+ENP	A	PTFE	1	RF	E	ELECTRIC ACTUATOR
BF	2 PIECE BALL VALVE	2	REDUCED	2	CLASS 300	B	A351-CF8(F304)	B	304	B	RTFE(GLASS)	2	RTJ		
BN	3-WAY BALL VALVE (90°)			3	CLASS 600	C	A351-CF8M(F316)	C	316	C	RTFE(CARBON)			P	PNEUMATIC ACTUATOR
BY	3-WAY BALL VALVE (120°)			4	CLASS 900	D	A351-CF3(F316L)	D	304L	D	SUPER TEFLON				
B6A	F6A BALL VALVE			5	CLASS 1500	E	A351-CF3M(F316L)	E	316L	E	PFA			G	GEAR OPERATOR
BFM	METAL SEAT BALL VALVE					F	A351-CN7M	F	ALLOY 20	F	PEEK				
BFC	CRYOGENIC BALL VALVE					G	A217-WC1	G	410	G	NYLON			B	BARE STEM
BP	POCKETLESS BALL VALVE					H	A217-WC6(F11)	Q	DUPLEX	H	METAL			L	LEVER
BJ	STEAM JACKET					J	A217-WC9(F22)	R	MONEL	I	PCTFE				
						K	A352-LCC	S	HASTELLOY	J	DEVLON®				
						L	A352-LC2	T	TITANIUM	K	GRAPHITE				
						M	A352-LC3	X	OTHER	X	OTHER				
						N	A352-LCB(LF2)								
						P	A217-C5								
						Q	DUPLEX								
						R	MONEL								
						S	HASTELLOY								
						T	TITANIUM								
						U	INCONEL								
						X	OTHER								

## DESIGN STANDARDS

### Item

### Standard

Shell Wall Thickness

Class 150, 300 and 600

ANSI B16.34

Pressure Temp Rating

ANSI B16.34

Pressure Test

Class 150, 300 and 600

API 598

Face to Face Dimensions

ANSI B16.10

End Flange Dimensions

ANSI B16.5

Mounting Pad Class 600

ISO 5211

Visual Casting Inspection

MSS SP-55

Fire Test

API 607 4th Edition & API 6FA

General Design Class 600

ANSI B16.34 & API 6D

Material Requirements

NACE MR0175 Latest Edition

Quality Control

API 6D

Valve Design & Construction

API 608

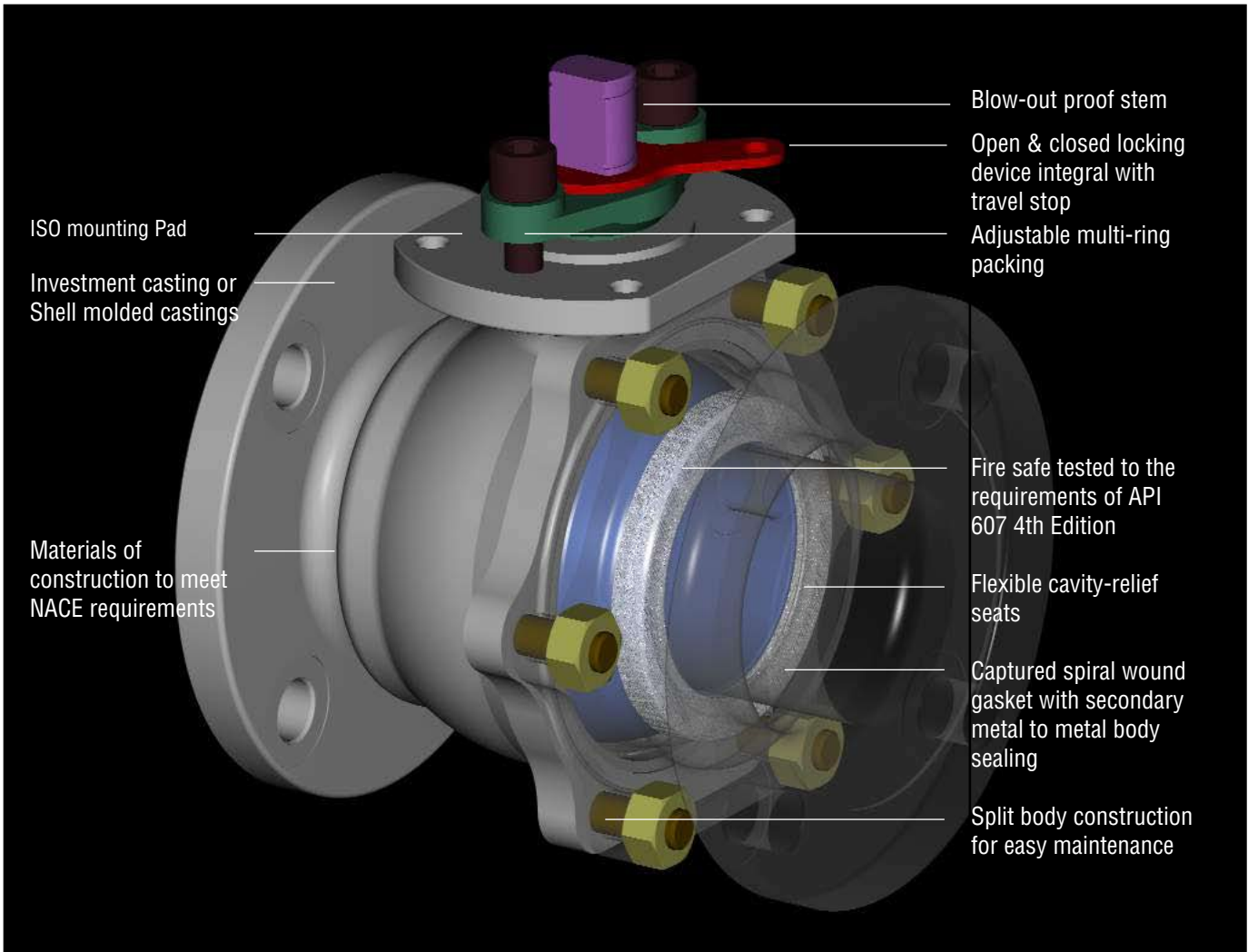

**APPLICABLE SEAT MATERIALS**

- PTFE
- RTFE (15% Glass Filled)
- RTFE ( 25% Carbon Filled)
- Super Teflon
- PFA Seat
- Peek Seat
- Nylon Seat
- Metal
- PCTFE
- Devlon®
- Graphite
- Other materials can be supplied upon request

**SPECIFICATIONS**

- Full Bore & Reduced Bore
- Floating Ball Design
- Locking Device
- Blow-Out Proof Stem
- Flexible Cavity Relief Seats
- Anti-Static Grounding Device
- ISO Mounting Pad
- Metal to Metal Construction
- Lip Seal or Plate Seal
- NACE Standard
- Fire Safe Design / Non Fire Safe Design
- Two Radius of Ball Edge for Long Life Cycle
- Double “D” Stem

# FLOATING BALL VALVE FEATURES

## General

FORCE floating ball valves are designed in accordance with API 608 or ISO17292(BS5351) for ANSI Class ratings 150 to 2500, Nominal sizes from 1/2" to 12". Valves have been designed for use with various combinations of materials such as; Carbon Steel, Low Carbon Steel, Special Alloy, Stainless Steel, Monel, Inconel.

## Body Joint Construction

The one piece unibody end entry design, graphite ring or o-ring, Viton (upon request) seals ensure absolute seal integrity. The two piece bolted body designs include a tight toleranced overlapping metal fit between the body and the adapter to minimize any possibility of movement due to pipeline stress. A special high temperature spiral wound stainless steel / grafoil filled gasket is utilized for absolute seal. This gasket is encapsulated by the body and adapted on all four sides. Body and adaptors are dimensioned for metal contact to ensure correct gasket crush.

## Blow-Out Proof Stem

Stem is made separately from the ball, anti blow-up design with suitable PTFE and graphite rings and antistatic device. The lower end of the stem is designed with an integral collar to be blowout-proof. It also functions as the backseat for assured stem sealing. (Fig. 1)

## Anti-Static Device

All floating flanged ball valves include dual grounding systems from stem to ball and stem to body. Valve testing to ISO17292(BS5351) was performed for all sizes, and witnessed by a third party inspection company. An antistatic feature is provided to ensure electrical continuity for assured stem sealing. (Fig. 2)

## Live Loaded Gland Flange

Live loading is designed to provide gland load retention, compensating for expected in-service consolidation of the packing. A set of Belleville-Spring Washers are used on each gland follower flange and therefore reduce fugitive emissions from the stem packing. FORCE standard Belleville-Spring Washers are protected by a weatherproof cap to keep them free from environmental contamination, resulting in a long stable life. (Fig. 3)

## Top Works

Stem head design provides mounting of the lever handle always in parallel to the flow passage. Facility for mounting a locking device for prevention of accidental valve operation is provided (Fig. 4)

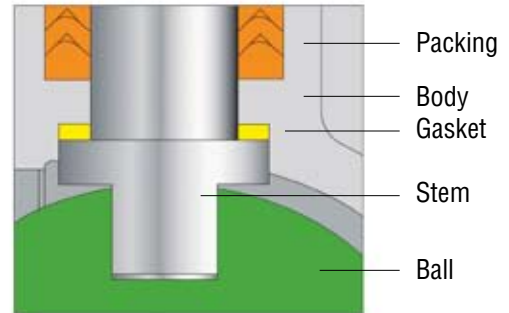

Fig. 1

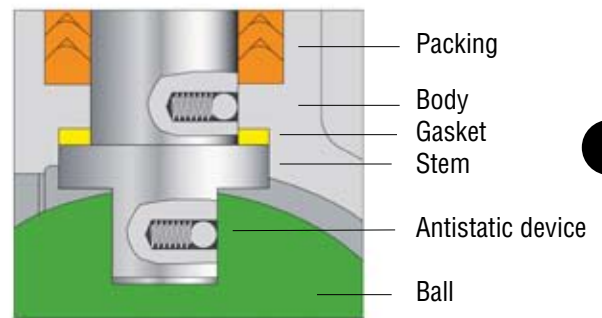

Fig. 2

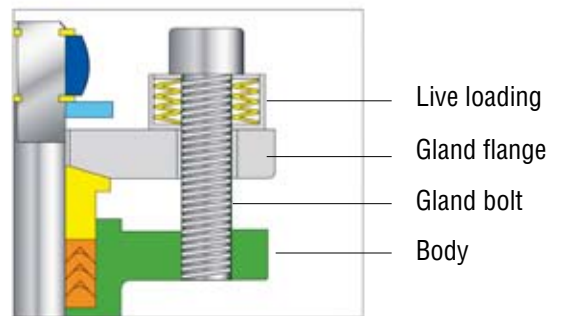

Fig. 3

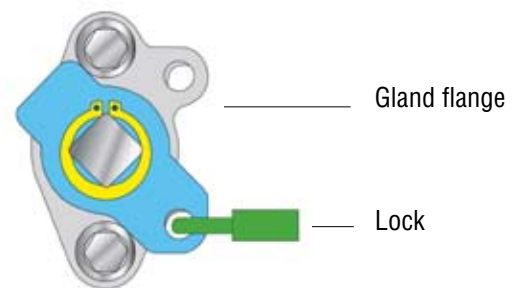

Fig. 4

## Fire Safety

All fire-safe valves conform to API 607 and API 6FA standards.

When a fire accident occurs at a jobsite where the valve is operating, components such as seat ring, stem back seat, stem packing and mid-flange gasket which made of non-metallic material such as PTFE were broken or destroyed. However, FORCE's particularly metal to metal added seal seated designed ball valves can effectively control external or internal leakage. FORCE's soft seated fire safety designed as follows:

### Longevity of Life

Special consideration was devoted to the attainment of enhanced life and operation of our valve throughout design, development, testing and manufacturing stages. Valve designs combined with the selection of advanced materials are such that long periods of inactivity should not affect the operations of efficiency.

### Contact between stem and valve shell

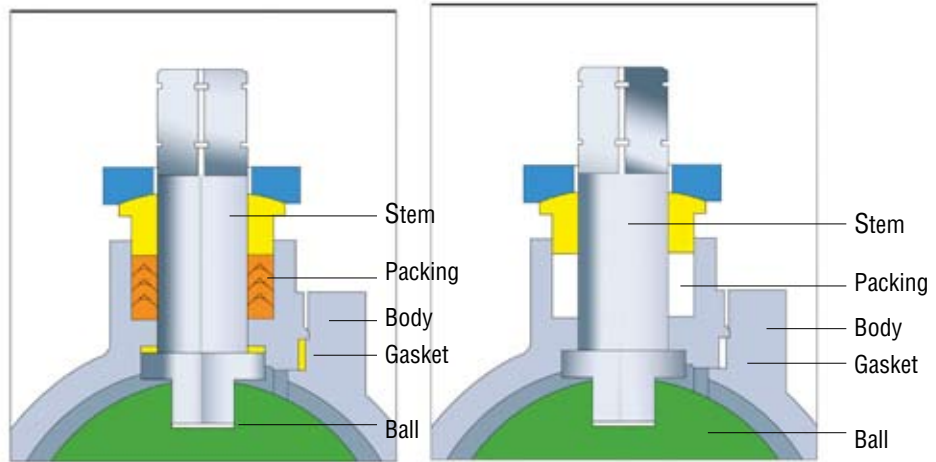

Fig. 5 (Before Fire)

Fig. 6 (After Fire)  
Metal-to-metal contact

### Contact between ball and valve shell

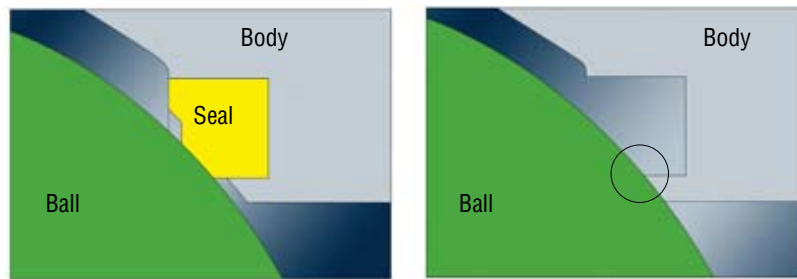

Fig. 7 (Before Fire)

Fig. 8 (After Fire)  
Metal-to-metal contact

### Valve shell coupling flanges of split body design

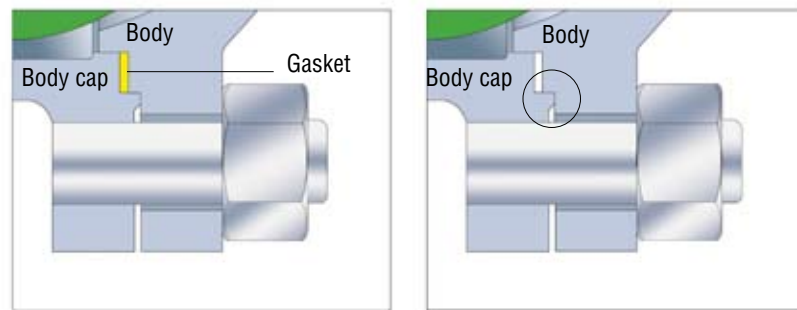

Fig. 9 (Before Fire)

Fig. 10 (After Fire)  
Metal-to-metal contact

# PARTS LIST AND MATERIAL SPECIFICATIONS (TYPICAL)

## MODEL BU

No.	Part Name	Qty.	Carbon Steel	Stainless Steel
1	Body	1	A216-WCB	A351-CF8M
2	Retainer	1	A216-WCB	A351-CF8M
3	Ball	1	A351-CF8M	A351-CF8M
4	Stem	1	A276-316	A276-316
5	Gland	1	A276-304	A276-304
6	Gland Flange	1	A351-CF8	A351-CF8
7	Stopper	1	A240-304	A240-304
8	Handle	1	Ductile Cast Iron	Ductile Cast Iron

No.	Part Name	Qty.	Carbon Steel	Stainless Steel
9	Thrust Washer	1	PTFE	PTFE
10	Gland Packing	1 Set	Graphite+Carbon Fiber	Graphite+Carbon Fiber PTFE
11	Seat	2	RTFE	RTFE
12	Gasket	1	Graphite	Graphite
13	Gasket	1	PTFE	PTFE
14	Stem Bearing	1 Set	RTFE	RTFE
15	Handle Bolt	1 Set	A193-B8	A193-B8
16	Gland Bolt	2	A193-B8	A193-B8

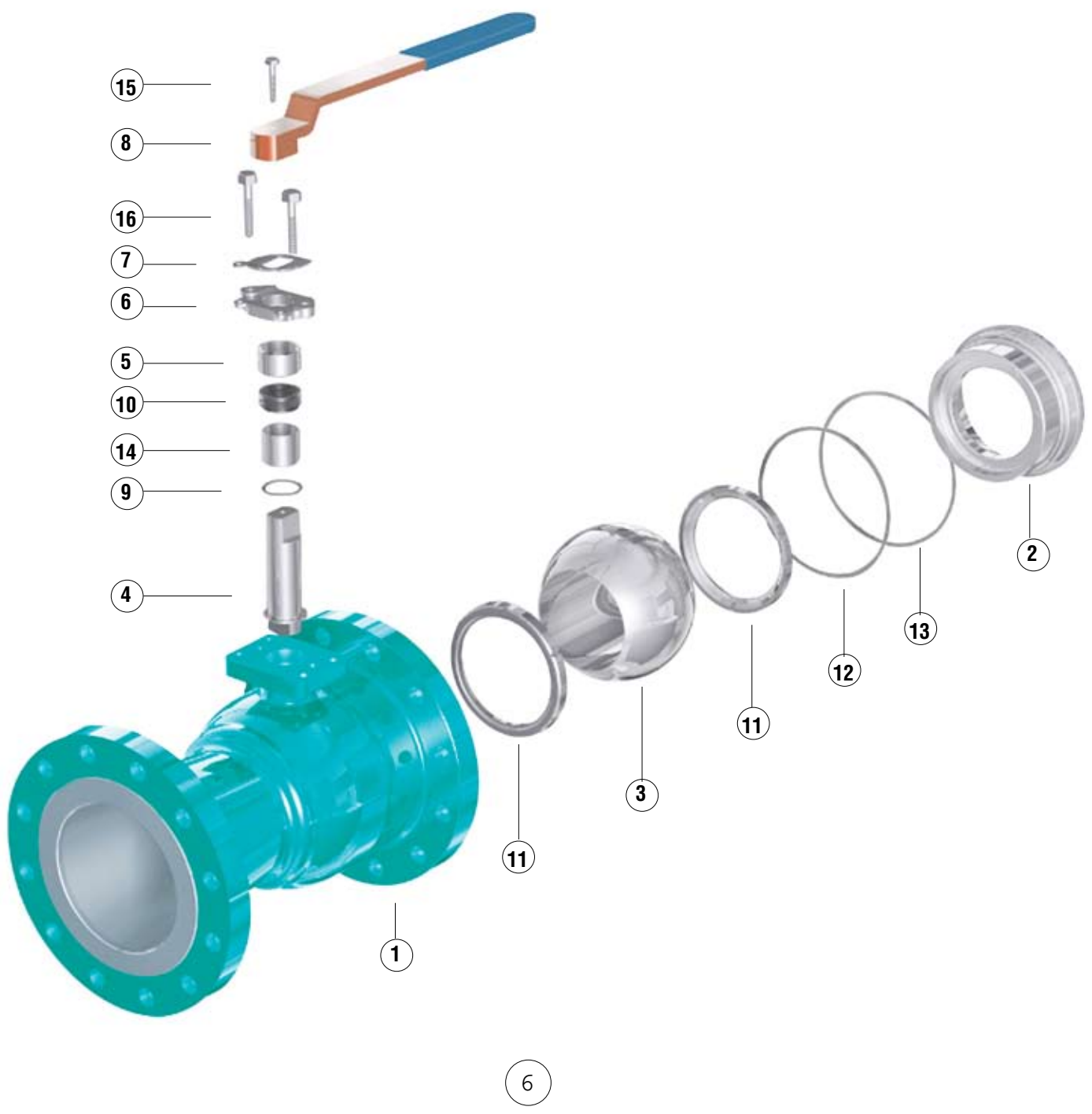

# ENGINEERING DATA

## MODEL BU

### Pressure / Temperature Ratings for Model BU

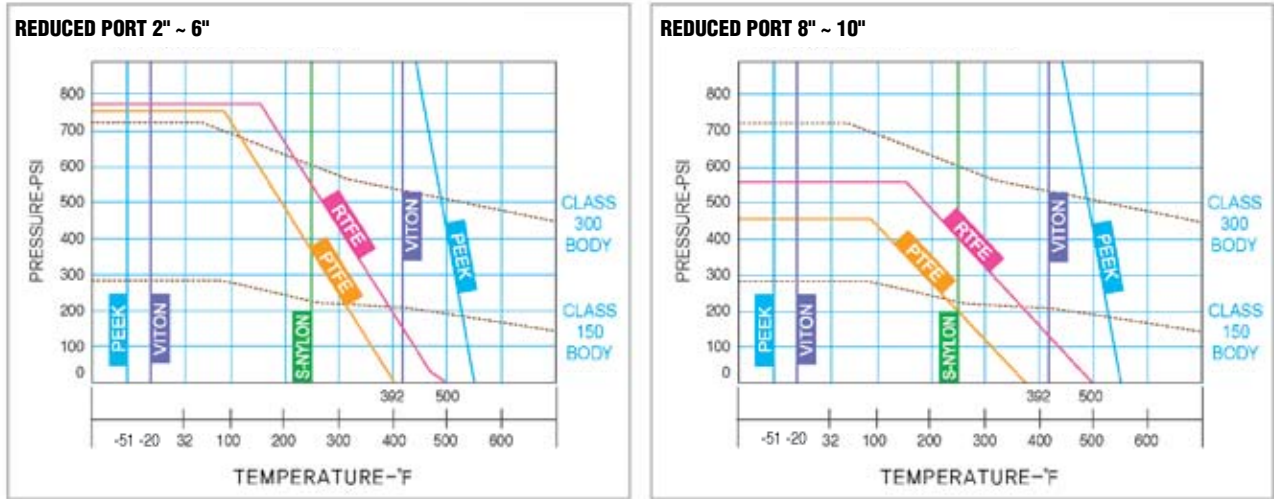

The dotted lines indicate Working Pressures for casting stainless steel bodies. (ASTM A351-CF8M)  
 The operating temperature of the valves is limited by the material of seat and seal.

### Torque Data for Model BU

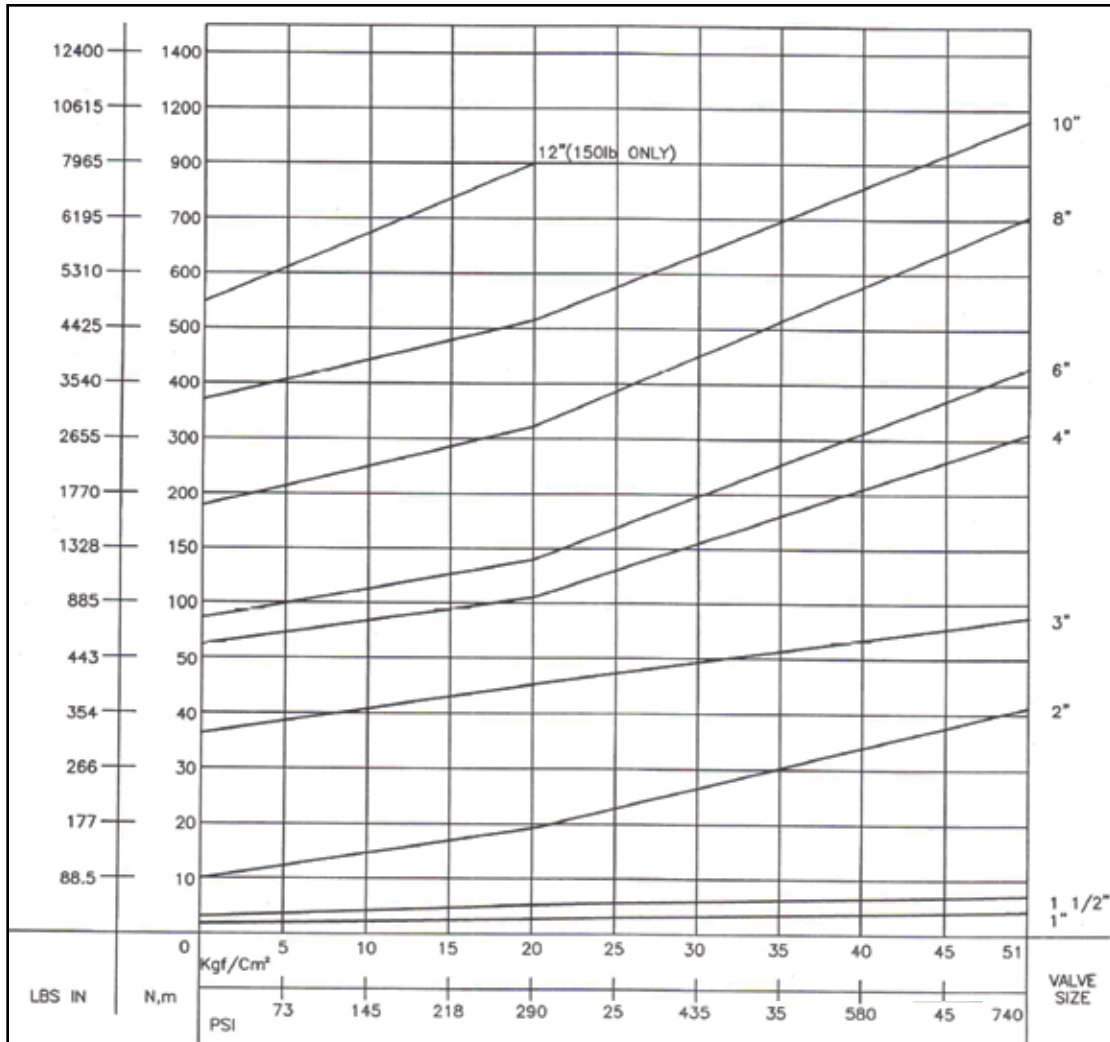

Seat Material: Reinforced PTFE. When selecting an actuator, add a 25% safety factor to the required torque.

# PARTS LIST AND MATERIAL SPECIFICATIONS (TYPICAL)

## MODEL BF

No.	Part Name	Qty.	Carbon Steel	Stainless Steel
1	Body	1	A216-WCB	A351-CF8M
2	Retainer	1	A216-WCB	A351-CF8M
3	Ball	1	A351-CF8M	A351-CF8M
4	Stem	1	A276-316	A276-316
5	Gland	1	A276-304	A276-304
6	Gland Flange	1	A351-CF8	A351-CF8
7	Stopper	1	A240-304	A240-304
8	Handle	1	A283-D, A536	
9	Thrust Washer	1	PTFE	PTFE

No.	Part Name	Qty.	Carbon Steel	Stainless Steel
10	Gland Packing	1 Set	Graphite+Carbon Fiber	Graphite+Carbon Fiber
11	Seat	2	RTFE	RTFE
12	Gasket	1	316Hoop+Graphite	316Hoop+Graphite
13	Stem Bearing	1	RTFE	RTFE
14	Cap Bolt	1 set	A193-B7	A193-B8
15	Cap Bolt Nut	1 set	A194-2H	A194-8
16	Gland Bolt	2	A193-B7	A193-B8
17	Handle Bolt	1	A193-B8	A193-B8

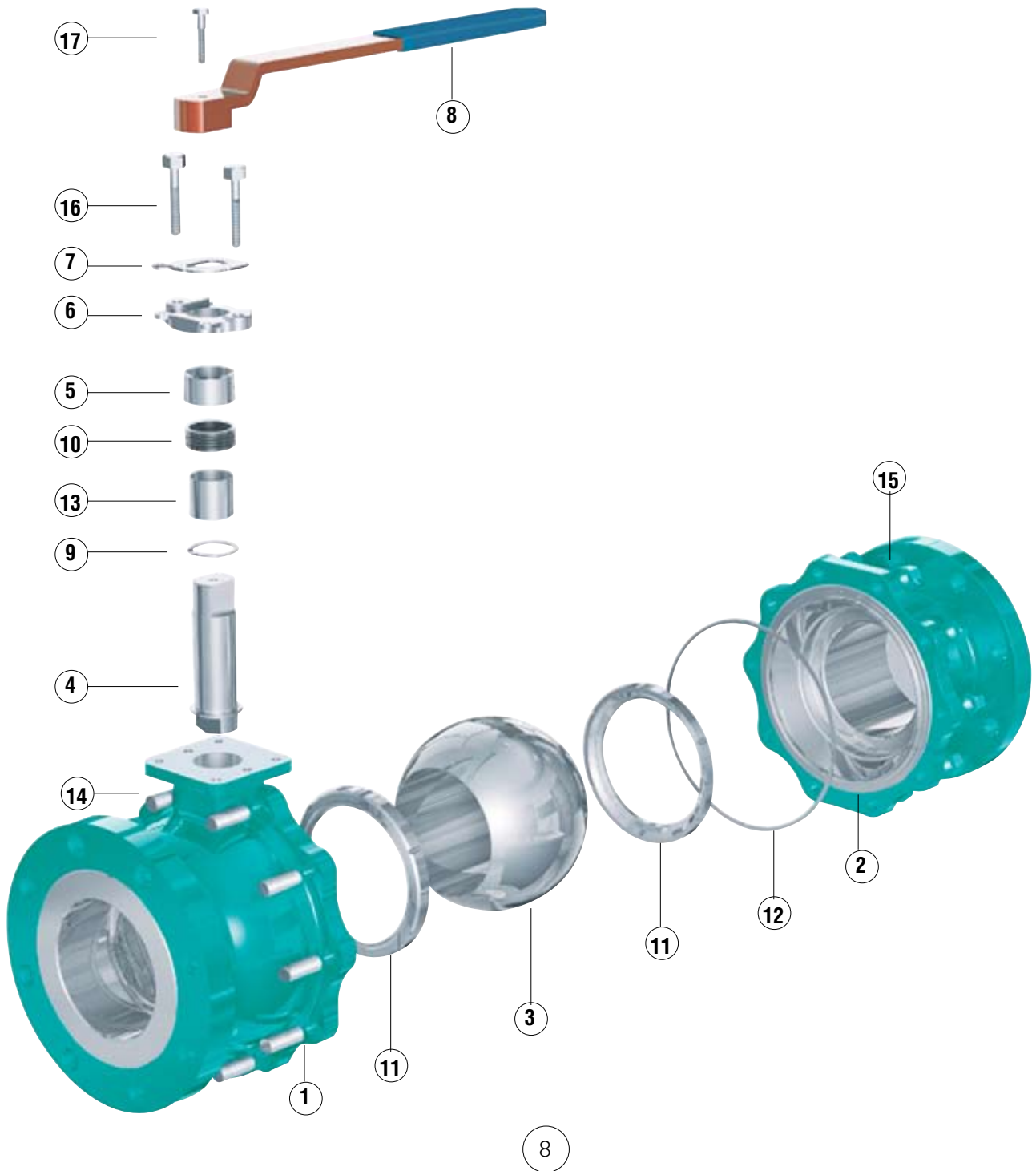

# ENGINEERING DATA

## MODEL BF

### Pressure / Temperature Ratings for Model BF

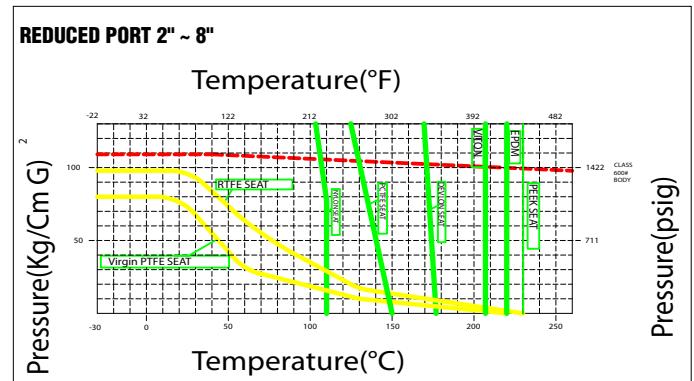
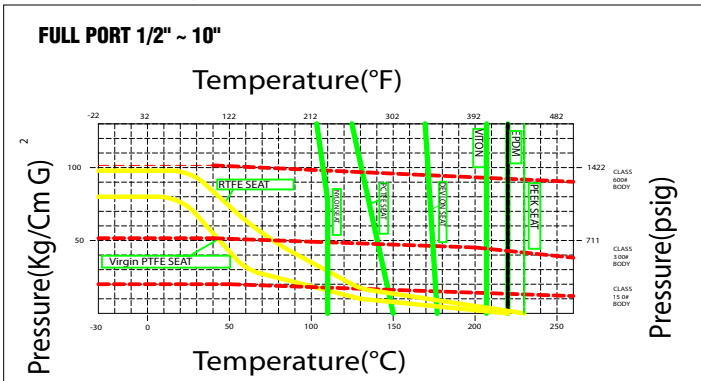

The dotted lines indicate Working Pressures for casting stainless steel bodies. (ASTM A351-CF8M)  
 The operating temperature of the valves is limited by the material of seat and seal.

### Torque Data for Model BF

**Nominal Operating Torque**  
 Class 150, 300, 600 Floating type ball valve

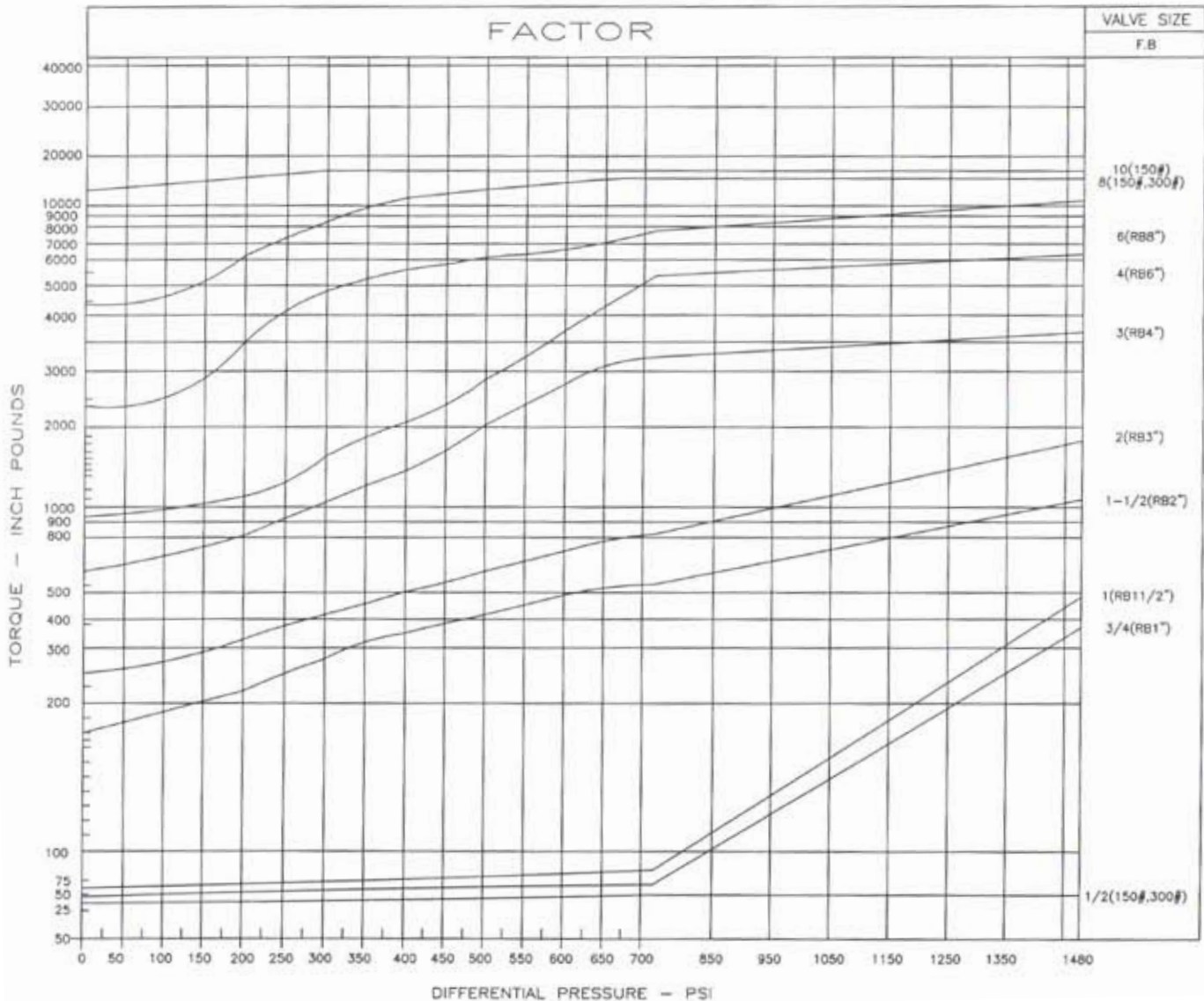

Seat Material: Reinforced PTFE. When selecting an actuator, add a 25% safety factor to the required torque.  
 For other sizes not listed, contact Force.

# FLOATING BALL VALVES ANSI 150 & 300

## BU Series

Reduced bore: sizes 1-1/2" to 12"  
 For pipeline, oilfield or process Industry

## Standard Materials

Body: Carbon Steel (WCB, LCB)  
 Stainless Steel (CF8, CF8M)  
 Ball: Stainless Steel (CF8, CF8M)  
 Stem: SS304, SS316  
 Seats: PTFE, RTFE, Modified TFE

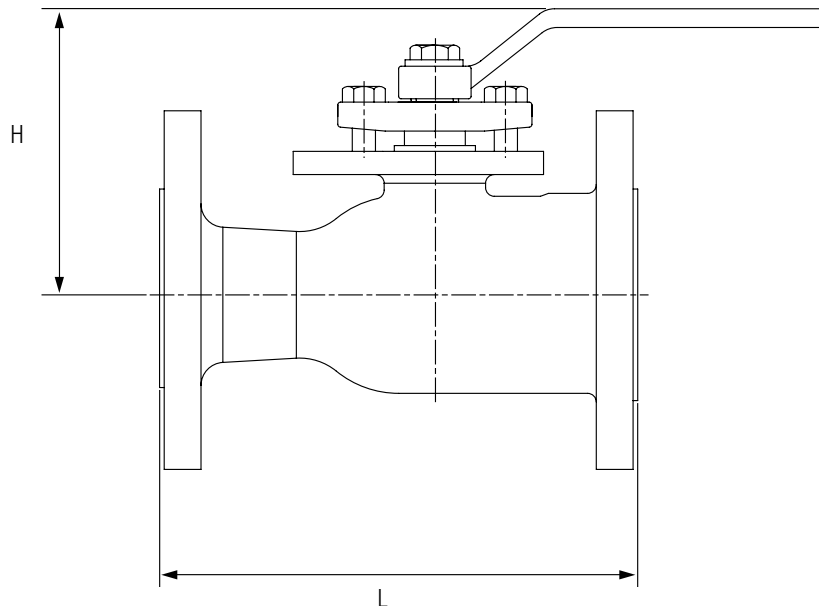

### CLASS 150 DIMENSIONS Units : inch / mm

NPS	1 1/2	2	2 1/2	3	4	6	8	10	12
d (Bore)	1	1.5	2	2.32	3	4	5.67	7.32	8.66
	25	38	51	59	76	102	144	186	220
L	6.5	7	7.5	8	9	10.5	11.5	13	14
	165	178	191	203	229	266.7	292	330	355.5
H	4	5	5.6	6.1	6.7	8.1	10.9	12.8	16.5
	102	127	142	154	170	206	278	325	419
Cv Value	106	153	276	317	449	899	1,180	3,277	4,350

### CLASS 300 DIMENSIONS Units : inch / mm

NPS	1 1/2	2	3	4	6	8	10
d (Bore)	1	1.5	2.32	3	4.1	5.67	7.4
	25	38	59	76	102	144	203
L	7.5	8.5	11.14	12	15.87	16.5	18
	191	216	283	305	403	419	459
H	4	5	6.1	6.7	8.1	10.9	12.8
	102	127	154	170	206	378	325
Cv Value	106	156	361	533	1,039	1,402	3,277

## FLOATING BALL VALVES ANSI 150 & 300

### BF Series

Full bore: sizes 1/2" to 12"

For pipeline, oilfield or process Industry

#### CLASS 150 DIMENSIONS Units : inch / mm

NPS	1/2	3/4	1	1 1/2	2	2 1/2	3	4	6	8	10	12
d (Bore)	0.5	0.75	1	1.5	2	2.5	3	4	6	8	10	12
	13	19	25	38	51	64	76	102	152	203	254	305
L	4.25	4.61	5	6.5	7	7.5	8	9	15.5	18	21	24
	108	117	127	165	178	191	203	229	394	457	533	610
H	3.3	3.5	4	5	5.6	6	6.7	8.1	13.1	16	18.9	21.3
	84	88	102	127	142	152	170	206	331	406	480	540
Cv Value	26	61	113	270	470	740	1,250	2,250	5,200	9,550	15,050	23,050

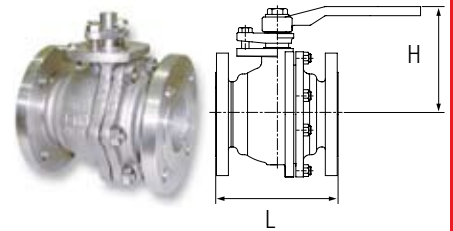

#### CLASS 300 DIMENSIONS Units : inch / mm

NPS	1/2	3/4	1	1 1/2	2	3	4	6	8	10
d (Bore)	0.5	0.75	1	1.5	2	3	4	6	8	10
	13	19	25	38	51	76	102	152	203	254
L	5.5	6	6.5	7.5	8.5	11.13	12	15.86	19.75	22.38
	140	152	165	191	216	283	305	403	502	568
H	3.3	3.5	4	5.2	5.8	6.8	8.1	13.1	16	18.9
	84	88	102	127	147	173	206	331	406	480
Cv Value	26	61	113	270	470	1,100	2,150	5,150	9,450	15,050

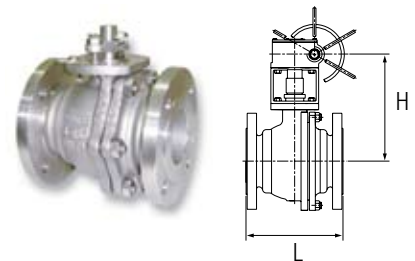

## FLOATING BALL VALVES ANSI 600

### BF Series

Full bore: sizes 1/2" to 6"

Reduced bore: sizes 2" to 8"

For oilfield or process Industry

#### CLASS 600 DIMENSIONS Units : inch / mm

NPS	1/2	3/4	1	1 1/2	2x 1 1/2	2	3X2	3X3	4X3	4X4	6X4	6X6	8x6
d (Bore)	0.51	0.75	1	1.5	1.5	2	2	3	3	4	4	6	6
	13	19	25	38	38	51	51	76	76	102	102	152	152
L	6.5	7.5	8.5	9.5	11.5	11.5	14	14	17	17	22	22	26
	165	190	210	241	292	292	356	356	432	432	559	559	660
H	3.54	3.66	3.94	4.96	4.96	5.31	5.6	6.7	6.7	8.1	8.1	13.1	13.1
	90	93	100	126	126	135	142	170	170	206	206	331	331
Cv Value	21	44	75	239	165	450	250	1,050	650	1,900	840	4,650	2,200

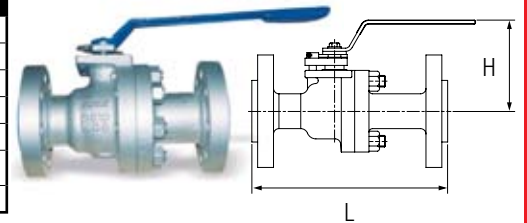

## FLOATING BALL VALVES ANSI 900 & 1500

### BF Series

Full bore: sizes 1/2" to 2"

For oilfield or process Industry

#### CLASS 900 & 1500 DIMENSIONS Units : inch / mm

NPS	1/2	3/4	1	1 1/2	2
d (Bore)	0.51	0.75	1	1.5	2
	13	19	25	38	51
L	8.5	9	10	12	14.5
	216	229	254	305	368
H	3.9	4	4.5	5.7	6.9
	99	102	115	144	176
Cv Value	14	34	60	180	380

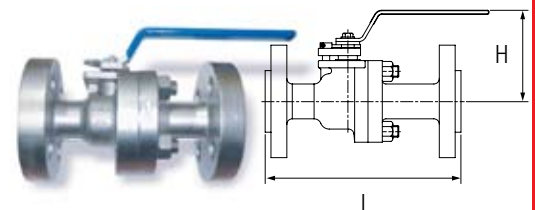

#### Standard Materials

Body: Carbon Steel (WCB, LCB)  
Stainless Steel (CF8, CF8M)  
Ball: Stainless Steel (CF8, CF8M)  
Stem: SS304, SS316  
Seats: RTFE, Nylon, PEEK

#### Standard Materials

Body: Carbon Steel (WCB, LCB)  
Stainless Steel (CF8, CF8M)  
Ball: Stainless Steel (CF8, CF8M)  
Stem: SS304, SS316  
Seats: Nylon, RTFE or Devlon®, PEEK

# MATERIALS

## BODY & TRIM MATERIAL

### CARBON STEEL

A 105                      A216 WCB                      A216 WCC

### LOW TEMPERATURE CARBON STEEL

A 350 LF2                      A352 LCB                      A352 LCC

### LOW ALLOY STEEL

AISI 4140                      A694 F65                      A694 F52  
 A694 F60                      A350 LF3  
 API 6A 60K(A694 F60 Mod)

### MARTENSITIC STAINLESS STEEL

A182 F6A                      A182 F6NM  
 A217 CA15                      A487 CA6NM

### AUSTENITIC STAINLESS STEEL

A182 F316                      A182 F316L  
 A182 F316LN-Mod.                      A182 F347  
 A182 F44(6% Mo)                      A182 FXM-19  
 (UNS S31254)                      (Nitronic 50)  
 A351 CF8M                      A351 CF3  
 A351 CF3M  
 PRECIPITATION HARDENING STAINLESS STEEL  
 A564 Gr 630 H 1150M (UNS S 17400)

### NICKEL ALLOYS

Incoloy 825 (UNS N08825)  
 Inconel 625 (UNS N06625)  
 Inconel 750 (UNS N07750)  
 Monel 400  
 Monel K500  
 Incoloy 925 (UNS N09925)  
 Inconel 718 (UNS N07718)

### DUPLEX STAINLESS STEEL

A181 F51 (UNS S31803)  
 A182 F53 (UNS S31750)  
 A182 F55 (UNS S31760)  
 A890-4A (UNS S31803)  
 A890-6A (UNS S32760)

## SEAT INSERT & SEAL MATERIALS OPERATING (DYNAMIC) LIMITS\*

MATERIAL	TEMP° C		PRESSURE CLASS	SEAL	SIZE	
	MIN.	MAX			SEAT INSERT	SEAL
Nylon SMX	-40	120	2500	N/A	64"	N/A
Lauramid (Nylon 12G)	-60	100	2500	N/A	64"	N/A
Devlon (Nylon 6)	-60	140	2500	N/A	64"	N/A
Peek	-60	220	2500	N/A	36"	N/A
PTFE Glass Filled (25%)	-100	200	600	N/A	24"	N/A
PTFE Carbon Filled (25%)	-100	180	300	N/A	24"	N/A
PCTFE	-196	150	2500	N/A	36"	N/A
HNBR-Therban	-40	150	600	2500	64"	64"
FKM A (Viton A)	-29	180	600	2500	64"	64"
FKM GLT (Viton GLT)	-40	180	600	2500	64"	64"
FKM AED	-29	180	600	2500	64"	64"
PTFE + Elgiloy Springs	-196	200	N/A	2500	N/A	36"

## SEAT INSERTS - OPERATING CONDITION\*

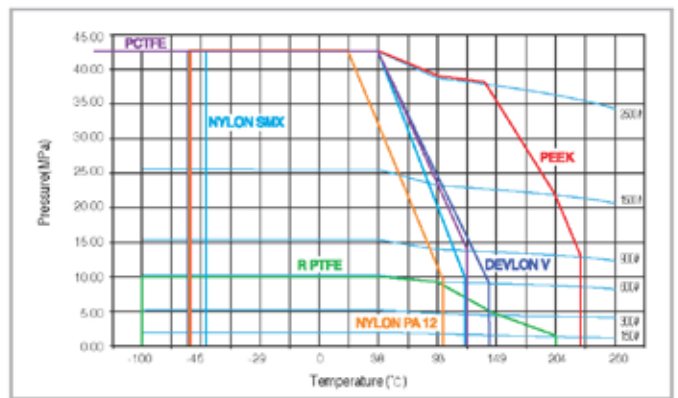
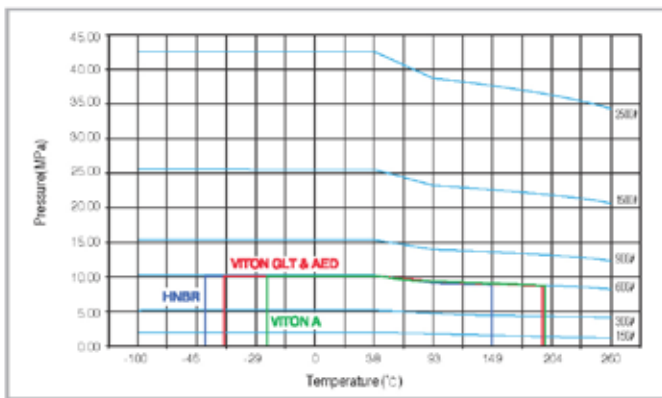

\*Given as reference only.

## MATERIAL FOR SEALING AND SEAT INSERT

Material	General Temperature Range	USE / Characteristics	Not Recommended for	Properties
FM (Viton A)	-13° F - 400° F (- 25° C ~ 204° C)	aliphatic hydrocarbons (petroleum oil, mineral oil/grease, fuel oils, butane, propane, natural gas), aromatic hydrocarbons (benzene, toluene), chlorinated hydrocarbons, high vacuum, most acids/chemicals	brake fluid with glycol base, ammonia gas, amines, alkalis, acetone, skydrol, ethyl acetate, superheated steam, polar solvents (ketone, acetone, acetic acid, etc), low molecular esters and ethers	excellent resistance for wear, ozone, weather, aging, compression set, permeation
FKM (Viton GLT)	-50° F - 400° F (-45° C ~ 204° C)	extended low temperature service over Viton A. Excellent for water, steam and mineral acids in addition to use of Viton A	same as those of Viton A	similar to those of Viton A except a little inferior compression set and permeability
NBR (Buna-N, Nitrile)	-35° F - 212° F (-37° C ~ 100° C)	aliphatic hydrocarbons (petroleum oil, mineral oil/grease, fuel oils, butane, propane, natural gas) dilute acids, alkali, and salt solutions at low temperature, water	fuels of high aromatic content aromatic hydrocarbons (benzene), chlorinated hydrocarbons, polar solvents (ketone, acetone, acetic acid, ethylene-ester), strong acid, glycol based brake fluid, ozone, weather and atmospheric aging	good resistance for wear, compression set, permeation
PTFE	-400° F - 450° F (-240° C ~ 232° F)	almost all chemicals and solvents including strong acid and alkali, high and very low temperature service.	high mechanical loading	weather resistance, thermal stability, low friction
Nylon 6 + MOS2	-65° F - 250° F (-54° C ~ 121° C)	aliphatic and aromatic hydrocarbons, ketones, acetone, ethers, weak alkalis, and acids, inorganic salt solutions	strong acids and alkali, strong ammonia, sodium hydroxide	excellent load bearing, strength and rigidity, self lubricating, good abrasion resistance
PEEK (polyetheretherketon)	-40° F - 500° F (-40° C ~ 260° C)	superb chemical resistance including alcohols, acids, ammonia, esters, halogenated organics, hydrocarbons and inorganics	some strong acids - nitric, chromic, sulfuric, benzene sulfonic acids and aqua regia, etc, some inorganics - bromine, chlorine and fluorine, etc.	good high temperature performance, wear resistance, very low smoke and toxic gas emission, good hydrolysis resistance
Polymite	- 65° F - 275° F 185° F, water based fluids (-54° C ~ 135° C)	petroleum and water based fluids, phosphate ester fluids, some chlorinated fluids and solvents, ketones, ethylene base glycols	strong acid, alcohols, brake fluids, dry chlorine, water over 185°F	very high sealability, tear strength, abrasion and extrusion resistance

## TEMPERATURE LIMITS OF METAL PARTS

Forging	Casting	Low Temperature	High Temperature
A105	A216 WCB	-20° F (-29° C)	800° F (426° C)
A350 LF2	A352 LCB, LCC	-50° F (-46° C)	650° F (343° C)
A182 F 316	A351 CF8M	-425° F (-254° C)	1500° F (815° C)

## TYPICAL GASKET SPECIFICATIONS

Type	Material	Low Temperature	High Temperature	Max. Pressure
Spiral wound	316 SS + Graphite	-420° F (-250° C)	1500° F (815° C)	6,250 psi (430bar)
Spiral wound	316 SS + PTFE	-200° F (-129° C)	450° F (232° C)	6,000 psi (415bar)

# GEAR ACTUATOR DATA

## Valve Automation

**FORCE**® is able to offer a comprehensive package of control equipment including actuators, switches, solenoids and positioners. Detail of actuator are available on request.

## Gear Operated

The gear operator can be furnished upon request

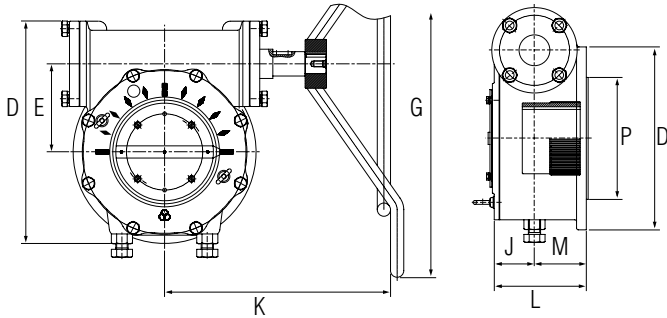

Model No.	Dimension	D	E	G	K	J	M	L	P	Flange Size	Gear Ratio	Max. Torque		Weight	
												inch	lb	N-m	lb
SBWG-00	inch	6.26	2.32	11.81	5.63	1.54	1.58	3.11	2.76	F10	34:1	11948	1350	13.23	6
	mm	159	59	300	143	39	40	79	70						
SBWG-01	inch	7.64	2.72	15.75	6.58	1.81	1.97	3.78	3.94	F14	42:1	19674	2223	24.25	11
	mm	194	69	400	167	46	50	96	100						
SBWG-02	inch	8.94	3.27	19.69	10.59	2.17	2.09	4.25	5.12	F16	42:1	24585	2778	41.89	19
	mm	227	83	500	269	55	53	108	130						
SBWG-03	inch	10.59	3.9	23.62	12.72	2.52	2.56	5.08	5.12	F16	43:1	30205	3413	74.96	34
	mm	269	99	600	323	64	65	129	130						
SBWG-04	inch	13.19	5.00	27.56	15.63	3.03	2.87	5.91	7.87	F25	50:1	40976	4630	119.05	54
	mm	335	127	700	397	77	73	150	200						
SBWG-04-1S	inch	13.19	5.00	27.56	15.63	3.03	2.87	5.91	7.87	F25	153:1	111466	12595	158.73	72
	mm	335	127	700	397	77	73	150	200						
SBWG-05	inch	15.75	6.30	31.5	17.72	3.03	3.15	6.18	9.06	F30	50:1	46834	5292	163.14	74
	mm	400	160	800	450	77	80	157	230						
SBWG-05-1S	inch	15.75	6.30	31.5	20.47	3.03	3.15	6.18	9.06	F30	153:1	130042	14694	202.82	92
	mm	400	160	800	520	77	80	157	230						
SBWG-06	inch	19.8	8.00	35.43	21.65	3.62	3.98	7.6	10.24	F35	55:1	57932	6546	302.03	137
	mm	503	203	900	550	92	101	193	260						
SBWG-06-1S	inch	19.8	8.00	35.43	23.62	3.62	3.98	7.6	10.24	F35	213:1	199514	22544	392.42	178
	mm	503	203	900	600	92	101	193	260						

# GENERAL TERMS AND CONDITIONS

NOTE: FORCE Industries Inc. and Seller will be used interchangeably.

1. **Warranty** - All of FORCE Energy Products Inc. (Seller) products are warranted to be free from manufacturing defects for a period of one (1) year from the date of shipment, and if found to be defective within that period the product will be replaced with no charge to Buyer, only if (1) the product was used as recommended and in accordance with approved installation and operating practices (2) product failure resulted from a manufacturing defect and not from damage in transit or damage due to corrosive, abrasive, or other wear normally to be expected in the use of the product involved and (3) that the written notice of such defect is delivered to FORCE Energy Products Inc during such on (1) year period. No labor cost or other expense or liability will be assume. THIS EXPRESS WARRANTY IS IN LIEU AND EXCLUDES ALL OTHER WARRANTIES, GUARANTEES, OR REPRESENTATIONS EXPRESS OR IMPLIED. THERE ARE NO IMPLIED WARRANTIES OR MERCHANTABILITY OR OF FITNESS FOR A PARTICULAR PURPOSE.
2. **PURCHASER'S REMEDIES** - The Purchaser's remedies with respect to any product furnished by FORCE Energy Products Inc. hereunder that is found not to be in conformity with the terms and conditions of the contract because of breach of contract, breach of express or implied warranty or negligence shall be limited exclusively to the right of replacement of such defective product or, at our option, repayment of our sale price of the product. In no event shall FORCE Energy Products Inc. be liable for claims (based upon breach of contract, breach of express or implied warranty, negligence or any other reason) for any other damages, whether direct, immediate, foreseeable, consequential or special or for any expenses incurred by reason of the use or misuse, sale or fabrication of products which do or do not conform to the terms and conditions of the contract.
3. **ACCEPTANCE OF ORDERS** - All orders are subject to acceptance by FORCE Energy Products Inc. No assignment of the Purchaser's rights may be made without the written consent of FORCE Energy Products Inc
4. **REMITTANCES** - All accounts are payable in United States funds free of exchange, collection, or any other charges. If in the sole discretion of FORCE Energy Products Inc., the financial condition of the Purchaser at any time so requires, FORCE Energy Products Inc. retains the right to require full or partial payment in advance. Terms: 30 Days
5. **PARTIAL SHIPMENTS AND PAYMENTS** - FORCE Industries Inc. reserves the right to make partial shipments from time to time, and to render invoices therefore which shall be due and payable as provided in said invoiced in the paragraphs above titled "Remittances" and "Terms of Payment" overleaf. If the Purchaser becomes overdue in any such partial payment, FORCE Energy Products Inc. shall be entitled to suspend work and/or avail itself of other legal remedies.
6. **TAXES** - Unless otherwise specifically noted, the amount of any sales, occupancy, excise tax, of any nature, federal, state or local for Seller is legally liable, either initially or through failure of payment by Purchaser, shall be in addition to the price quoted and Purchaser agrees to pay the same to FORCE Energy Products Inc.
7. **SHORTAGES AND DAMAGES IN TRANSIT** - All claims for loss, damages, shortages, etc. must be made within five days after receipt of shipment, but loss or damage to materials in transit is the responsibility of the carrier.
8. **DELAYS** - All promises of shipment are estimated as closely as possible, and FORCE Energy Products Inc. will use our best efforts to ship within the time promised but do not guarantee to do so, and assume no liability for not doing so. Materials stated to be in stock are subject to prior sale.
9. **CHANGES, CANCELLATION AND SUSPENSION** - The order or contract are subject to change, cancellation or instruction to suspend or delay work or delivery only upon receipt of written notification and consent. Orders for special fittings (usually P.O.A. items) may be changed and/or cancelled only upon receipt of written instructions with a tacit understanding and agreement to make payment for work already performed and material used.
10. **RETURN OF MATERIAL** - No product of Seller may be returned without Seller's written consent. All goods returned are subject to a handling charge plus freight in both directions and charges for any required reconditioning, unless otherwise specified in writing by FORCE Industries Inc.
11. **GOVERNING LAW** - The contract shall be governed by, construed, and enforced in accordance with the laws of the State of Texas.
12. **NO WAIVER** - The failure of Seller, to insist, in any one or more instances, upon the performance of any of the terms, covenants, or conditions of the contract or to exercise any right there under shall not be construed as a waiver or relinquishment of the future performance of any such term, condition, or the exercise of any other rights under the contract.
13. **PURCHASER'S ACCEPTANCE OF ABOVE CONDITIONS** - FORCE ENERGY PRODUCTS INC. IS NOT BOUND BY ANY TERMS ON THE PURCHASER'S ORDER FORM OR ANY OTHER DOCUMENT EMANATING FROM THE PURCHASER WHICH ATTEMPT TO IMPOSE ANY CONDITION AT VARIANCE WITH SELLER'S TERMS AND CONDITIONS OF SALE WHICH ARE INCLUDED HEREIN OR STATED ON SELLER'S PACKAGES, INVOICES AND TECHNICAL DATA SHEETS. SELLER'S FAILURE TO OBJECT TO PROVISIONS CONTAINED THE AFORMENTIONED FORMS OF THE PURCHASER SHALL NOT BE DEEMED A WAIVER OF THE PROVISIONS OF C&C INDUSTRIES INC.'S TERMS AND CONDITIONS OF SALE WHICH SHALL CONSTITUTE THE ENTIRE CONTRACT BETWEEN SELLER AND THE PURCHASER. NO WAIVER ALTERATION OR MODIFICATION OF THE TERMS AND CONDITIONS IN THIS DOCUMENT SHALL BE BINDING UNLESS IN WRITING AND SIGNED BY AN AUTHORIZED REPRESENTATIVE OF SELLER STENOGRAPHIC OR CLERICAL ERRORS ARE SUBJECT TO CORRECTION.
14. **FREIGHT POLICY** - All prices and shipments are F.O.B, Houston, Texas. Seller's responsibility ceases after Seller makes the delivery to the carrier. Claims for damages, loss or delay in transit should be made to the carrier. Full freight will be allowed on individual orders of \$5,000.00 net or more within the lower 48 states. Individual orders totaling less than \$5,000.00 net are not subject to freight allowance. Allowances are based on lowest published rates for rail or motor freight to all rail points listed in published tariffs. Freight allowances do not include delivery to building sites beyond these rail or highway points. Whenever a buyer specifies a more expensive method of shipment, the difference in transportation cost is for buyer's account.



Trunnion Ball Valves also available



**CCTX FLOW PRODUCTS, INC.**

8519 McIntyre  
Edmonton, Alberta  
Canada T6E 4Y1  
Phone: 780-466-3024  
Fax: 780-466-3451



**C&C INDUSTRIES, INC.**

10350 Clay Road, Suite 150  
Houston, Texas 77041  
Toll Free: 1.877.996.9911  
Phone: 713.466.1644  
Fax: 713.466.1715